



# **TF02-Pro-W-485**

## **User Manual**



# PREFACE

---

Dear users:

Thank you for choosing Benewake products. In the purpose of offering better operation experience to you, we hereby write this manual for an easier and simpler operation of our product, hoping to better solve the common problems you may meet.

This user manual contains relevant information on product introduction, usage and maintenance of TF02-Pro-W-485, covers the product operation introduction and common problem solutions. Please read this manual carefully before using the product. Remember the precautions to avoid hazards, and please follow the described steps in the manual when using it.

If you have any problems in the process of using, you are welcome to contact Benewake at any time for help.

## Contact Details

Official website: [en.benewake.com](http://en.benewake.com)

TEL: +86-10-57456983

Technical questions, please contact: [support@benewake.com](mailto:support@benewake.com)

Consult sale information or request brochure, please contact: [bw@benewake.com](mailto:bw@benewake.com)

## Headquarters Address

Benewake (Beijing) Co., Ltd.

3rd Floor, Haiguo Jiaye Sci-Tech Park, Haidian District, Beijing, China

## Copyright Statement

This User Manual is copyright © of Benewake. Please do not modify, delete or translate the description of this manual contents without the official written permission from Benewake.

## Disclaimer

As our products are constantly improving and updating, the specifications of TF02-Pro-W-485 are subject to change. Please refer to the official website for latest version.

# CONTENTS

---

<b>1</b>	<b>OVERVIEW .....</b>	<b>1</b>
	1.1 Technical Specification .....	1
	1.2 Maintenance and Cleaning .....	2
	1.3 Appearance and Structure .....	2
	1.4 Storage .....	4
<b>2</b>	<b>INTERFACE .....</b>	<b>5</b>
	2.1 Description About Wiring Sequence .....	5
	2.2 Electrical Characteristics .....	5
<b>3</b>	<b>WIPER WORKING .....</b>	<b>6</b>
<b>4</b>	<b>COMMUNICATION PROTOCOL .....</b>	<b>7</b>
	4.1 RS-485 Communication Interface .....	7
	4.2 Modbus Protocol .....	7
	4.2.1 Description about frame format .....	7
	4.2.2 Function Code .....	8
	4.2.3 Register Address .....	8
	4.3 Parameter Configuration .....	9
	4.4 Configuration Example .....	11

# 1 OVERVIEW

TF02-Pro-W-485 is a single-point ranging LiDAR based on upgraded TF02-Pro-W using ToF (Time of Flight) principle. It has been optimized in communication interface, input voltage and reverse voltage protection, adapted to the needs of industrial scenarios.

## 1.1 Technical Specification

Table 1- 1 Technical specification of TF02-Pro-W-485

Type	Parameters		Value
Product performance	Operating range	90% reflectivity, 0Klux	0.1m~25m
		10% reflectivity, 0Klux	0.1m~12m
		90% reflectivity, 100Klux	0.1m~25m
		10% reflectivity, 100Klux	0.1m~12m
	Accuracy <sup>①</sup>		±6cm (0.1m~6m) , ±1% (6m~25m)
	Distance resolution <sup>①</sup>		1cm
	Frame rate <sup>②</sup>		1Hz~1000Hz ( adjustable, default 100Hz)
	Repeatability <sup>①</sup>		1σ: < 2cm (0.1m~25m@90% reflectivity )
	Ambient light immunity		100Klux
	Enclosure rating		IP5X
Optical parameters	Photobiological safety		Class1 (IEC60825)
	Central wavelength		850nm
	Light source		VCSEL
	FoV <sup>③</sup>		3°
Electrical parameters	Supply voltage		DC 7V~30V
	Average current		≤200mA@12V
	Power consumption		≤4.8W
	Peak current		400mA@12V
Others	Dimension		85mm×59mm×43mm (L×H×W)
	Housing		PC/ABS
	Operating temperature		-20°C~60°C

	Storage temperature	-30°C~80°C
	Weight	92g (with cables)
	Cable length	120cm



**Note**

- ① The detection range is measured with the standard white board (90% reflectivity).
- ② The frame rate can be adjusted. The default value is 100Hz and the maximum value is 1000Hz, customized frame rate should be calculated by the formula:  $2000/n$  (n is an integer with  $\geq 2$ ).
- ③ The angle is a theoretical value, the actual angle value has some deviation.

## 1.2 Maintenance and Cleaning

- Before switching on, please check if the exposed window mirror is clean, and clean it promptly if it is dirty.
- After using the device, check the optics. If they are contaminated, please clean it promptly.
- The optics should be cleaned regularly if the device be operated in a severe environment for a long time.
- Before regular cleaning, please disconnect the power. Using a soft cloth to gently wipe the window in the same direction when the device is not operating, to avoid repeated wiping and damage to the window mirror.
- Do not remove the dust-removal wiper, which may cause equipment failure. If the dust-removal wiper is abnormal, please contact [bw@benewake.com](mailto:bw@benewake.com).
- When the steering shaft is blocked by dust for a long time, the steering shaft may be damaged due to the increased resistance. Please clean the steering shaft regularly.
- If you require deep cleaning of internal optics, please contact [bw@benewake.com](mailto:bw@benewake.com) to offer professional advice.

## 1.3 Appearance and Structure

The appearance and dimensions of TF02-Pro-W-485 are shown in Figure 1- 1 and Figure 1- 2.



Figure 1- 1 Appearance of TF02-Pro-W-485

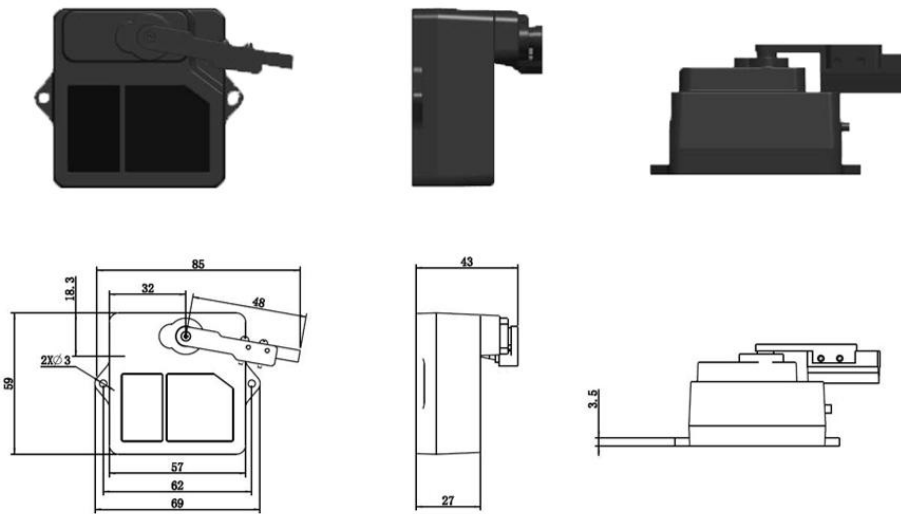

Figure 1- 2 Dimension of TF02-Pro-W-485 (unit: mm)

TF02-Pro-W-485 is recommended to use M2.5 round Phillips screws for installation. Please remove the protective film of the optical lens before use. The lens of front panel of LiDAR cannot be covered. Please keep it clean. The surface of optical lens is the ranging zero of LiDAR.

The detection angle of TF02-Pro-W-485 is 3°. At different distances, the size of light spot, namely the edge length of the detection range, is different, as shown in Figure 1- 3. Side length of the detection range at different distances (the detection range is a square), as shown in Table 1- 2.

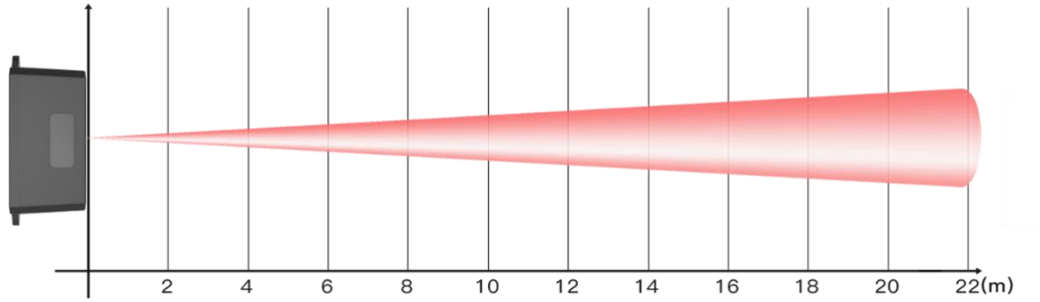

Figure 1- 3 Light spot size at different distances

Table 1- 2 Spot Size at Different Distances

Distance(m)	1	2	3	4	5	6	7	8	9	10	15	20	22
Spot size(cm)	5	10	16	21	26	31	37	42	47	52	79	105	115



**Note**

The side length of target object generally should be larger than size of the TF02-Pro-W-485 light spot; if the side length of the detected object is smaller than size of light spot, the output (Distance) from TF02-Pro-W-485 will be a value between the actual distance values of the two objects.

## 1.4 Storage

- Device should be stored at -30°C to 80°C with a relative humidity ≤ 60% and ventilation free from corrosive gases.
- Before storage, please make sure that all connections are disconnected or dust covers are inserted or covered to ensure cleanliness.
- If storage time is over three months, please carry out a working test before using, to ensure that the device can be used in normal condition.
- For ensuring the product performance, do not open the product shell or remove the IR-pass filter.

## 2 INTERFACE

---

### 2.1 Description About Wiring Sequence

The external tail cable of TF02-Pro-W-485 has no connector by default, the wiring sequence is shown in Table 2- 1.

Table 2- 1 The function description of each wire

Wiring color	Function	Comment
Red	VCC	Power supply
Black	GND	Ground
White	RS-485-B	DATA-
Green	RS-485-A	DATA+

### 2.2 Electrical Characteristics

TF02-Pro-W-485 has over-voltage and reverse polarity protection, but do not connect to power rails higher than 36V, reverse polarity protection voltage is -30V. The electrical characteristics are shown in Table 2- 2.

Table 2- 2 Main electrical parameters of TF02-Pro-W-485

Parameter	Value
Supply voltage	DC 7V~30V
Average current	≤200mA@12V
Peak current	400mA@12V
Average power consumption	≤4.8W
Communication level	RS-485



## 3 WIPER WORKING

---

The dust-removal wiper works in a fixed cycle, having a dust-removal operation every 4 hours in the default working mode. Each dust-removal operation is driven by the LiDAR servo, the wiper moves backwards and forwards for one time. And TF02-Pro-W-485 will also perform dust-removal operation once after each power-on. In addition, customer can control the LiDAR immediately by sending command for dust-removal, and modify the wiper swing times and save the settings. During the dust removal operation, the LiDAR does not measure and output data.

The wiper stops at position A when it does not work, and moves from position A to position B during operation, then returns to position A, the initial and termination positions are shown in Figure 3- 1.

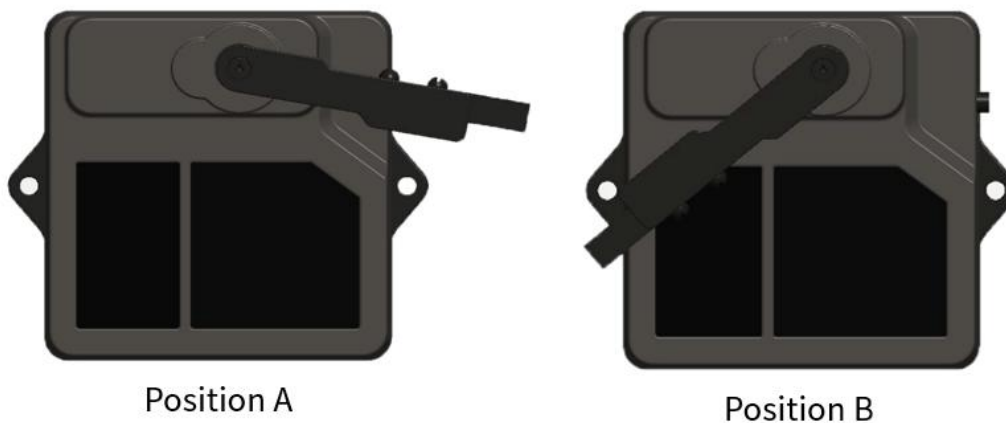

*Figure 3- 1 The initial and termination positions of the wiper movement*



**Note**

It is recommended that the dust-removal interval should be kept greater than 30 minutes, when servo is in high temperature environments (ambient temperature > 40 °C).

---

# 4 COMMUNICATION PROTOCOL

## 4.1 RS-485 Communication Interface

TF02-Pro-W-485 uses RS-485 communication standard with 2-wire interface, the communication protocol parameters are shown in Table 4- 1. The default baud rate is 115200, the default slave ID is 0x01.

Table 4- 1 TF02-Pro-W-485 RS-485 communication protocol

<b>Communication interface</b>	<b>RS-485</b>
<b>Default baud rate</b>	115200
<b>Data bit</b>	8
<b>Stop bit</b>	1
<b>Parity check</b>	None



### Warning

TF02-Pro-W-485 supports 9600, 14400, 19200, 38400, 43000, 57600, 76800, 115200 (default), 128000, 230400, 256000, 460800, 921600, 1382400 baud rates. It is not recommended to use the baud rate above 115200.

## 4.2 Modbus Protocol

### 4.2.1 Description about frame format

When TF02-Pro-W-485 Modbus protocol is enabled, the Modbus reading distance command format is shown in Table 4- 2.

Table 4- 2 The Modbus reading distance command format

Address field	Function code	Register address		Register number		CRC_Low	CRC_High
01	03	00	00	00	01	xx	xx

The data frame returned by TF02-Pro-W-485 is as follows:

Table 4- 3 The data frame format

Address field	Function code	Data length	Dist_High	Dist_Low	CRC_Low	CRC_High
01	03	02	XX	XX	xx	xx

### 4.2.2 Function Code

The function code of TF02-Pro-W-485 is shown in Table 4- 4.

Table 4- 4 The function code of TF02-Pro-W-485

Function code	Description
03	Read register
06	Write register

### 4.2.3 Register Address

- All register addresses are hexadecimal and register values are 16 bits;
- After setting parameter, save settings and restart LiDAR to take effect.

#### 4.2.3.1 Register Address for Reading Function Code

Table 4- 5 Register address list using function code: 0x03(read only)

Register address	Definition	Description
00 00	Dist	Distance, unit: cm
00 01	Strength	Signal strength
00 03	High 16bit of timestamp	2 high-order bits of timestamp represent relative time of LiDAR start up, unit: ms
00 04	Low 16bit of timestamp	2 low-order bits of timestamp represent relative time of LiDAR start up, unit: ms
00 06	High 16bit of software version	00 + major version number
00 07	Low 16bit of software version	Minor version number + revised version number

#### 4.2.3.2 Register Address for Writing Function Code

Table 4- 6 Register address list using function code: 0x06(write only)

Register address	Definition	Description
00 80	Save settings	Write any value to save settings
00 81	Power off/restart	Register value: 0-Power off (unavailable currently); 1-Restart
00 82	Disable Modbus	Register value:

		1-Disable Modbus; Others-Error reply
00 83	Baud rate High	Set baud rate. Restart to take effect
00 84	Baud rate Low	Set baud rate. Restart to take effect
00 85	Slave ID	Set slave ID. Restart to take effect (default 0x01)
00 86	FPS	Set frame rate. Restart to take effect (default 100Hz)
00 87	Working mode	Set working mode. Restart to take effect after saving settings. Register value: 0- Continuously detection mode(default) 1-Trigger mode Others-Error reply
00 88	Low-power consumption mode	Set low-power consumption mode, Restart to take effect after saving settings. Register value: 0-Disable(default) >0 and ≤10-Enable (the value is inside sampling frequency.)
00 89	Restore defaults	Write any value. Restart to take effect after saving settings.
00 8A	Start the wiper	Write any value. Start the wiper at any time.
00 8C	Modify dust-removal cycle	Unit: minutes (default 240 minutes). Take effect immediately.
00 8D	Modify number of wiper swings	The number should between 1 and 10 (default once). Take effect immediately.

### 4.3 Parameter Configuration

Table 4- 7 TF02-Pro-W-485 general parameter configuration under serial link mode

Function	Command	Response	Description
Enable Modbus	5A 05 15 01 75	5A 05 15 01 75	Save settings and restart to take effect.
Save setting	5A 04 11 6F	5A 05 11 00 70	

Table 4- 8 TF02-Pro-W-485 general parameter configuration with Modbus instructions

Function	Command	Response	Description
----------	---------	----------	-------------

Read distance	01 03 00 00 00 01 84 0A	01 03 02 DH DL CL CH	DH: 8 high-order bits of distance DL: 8 low-order bits of distance CL: 8 low-order bits of CRC CH: 8 high-order bits of CRC
Read distance and strength	01 03 00 00 00 02 C4 0B	01 03 04 DH DL SH SL CL CH	DH: 8 high-order bits of distance DL: 8 low-order bits of distance SH: 8 high-order bits of signal strength SL: 8 low-order bits of signal strength CL: 8 low-order bits of CRC CH: 8 high-order bits of CRC
Read firmware version	01 03 00 06 00 02 24 0A	01 03 04 00 VM VS VC CL CH	The software version is VM.VS.VC
Set baud rate	01 06 00 83 BH1 BH2 CL CH 01 06 00 84 BL1 BL2 CL CH	01 06 00 83 BH1 BH2 CL CH 01 06 00 84 BL1 BL2 CL CH	BH1, BH2, BL1, BL2 are high, secondary high, secondary low and low bytes of baud rate. E.g., set baud rate to 9600 (0x00002580) BH1=00 BH2=00 CL=78 CH=22 BL1=25 BL2=80 CL=D2 CH=D3
Set slave ID	01 06 00 85 IH IL CL CH	01 06 00 85 IH IL CL CH	IH, IL are high and low bytes of ID. For example, set ID to 2, IH=00 IL=02 CL=19 CH=E2
Set frame rate	01 06 00 86 FH FL CL CH	01 06 00 86 FH FL CL CH	FH, FL are high and low bytes of frame rate. E.g., Set frame rate to 100 (0x0064), FH=00 FL=64 CL=69 CH=C8
Set low-power consumption mode	01 06 00 88 LH LL CL CH	01 06 00 88 LH LL CL CH	LH, LL are high and low bytes of low power sampling rate. For example, set it to 5HZ low-power consumption mode, LH=00 LL=05 CL=C9 CH=E3
Save settings	01 06 00 80 00 00 88 22	01 06 00 80 00 00 88 22	Save settings and restart LiDAR to take effect
Disable Modbus	01 06 00 82 00 01 E8 22	01 06 00 82 00 01 E8 22	Save settings and restart LiDAR to take effect
Start the wiper	01 06 00 8A 00 00 A8 20	01 06 00 8A 00 00 A8 20	Start the wiper at any time
Modify dust	01 06 00 8C PH	01 06 00 8C PH	PH, PL are high and low bytes of cycle.

removal cycle	PL CL CH	PL CL CH	E.g., making wiper works every 240 minutes (0x00F0), PH=00 PL=F0 CL=48 CH=65
Modify the number of wiper round trips	01 06 00 8D WH WL CL CH	01 06 00 8D WH WL CL CH	WH, WL are high and low bytes of number of round trips. The number should between 1 and 10. E.g., twice each time  WH=00 WL=02 CL=98 CH=20



**Warning**

TF02-Pro-W-485 Only supports RTU mode to communicate in serial link.

## 4.4 Configuration Example

1) Under RS-485 serial link mode, enable Modbus protocol:

5A 05 15 01 75 // Enable Modbus protocol

5A 04 11 6F // Save setting

Restart and enter Modbus mode.

2) Under Modbus mode, disable Modbus Protocol:

01 06 00 82 00 01 E8 22 // Default address 01, disable Modbus

01 06 00 80 00 00 88 22 // Default address 01, save setting

Restart and exit Modbus.